

PLN GROUP



LUNAR POD LITE

Designed by IQ Commercial

LUNAR POD LITE

Designed by IQ COMMERCIAL

PLN GROUP

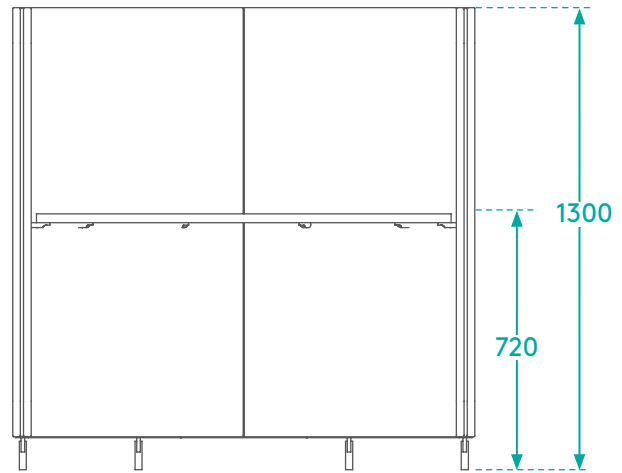
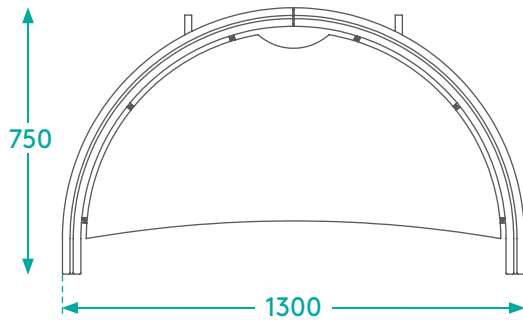

Dimensions 1300L x 750W x 1300H

About

Lunar Focus Pod Lite is a destination touch-down point which offers a privacy for individual focused work.

The soft, upholstered walls absorb noise common in today's open-plan office and provide shelter from both visual and acoustic distractions.

Easily installed and relocated, the pods are ideal for the agile workspace. Four lockable castors enable maximum mobility.



Specifications

- High-quality materials and premium upholstery for long-lasting durability.
- Light-weight MDF frame, water-based glues
- Worktops available in Standard Melteca (LPL) with edgebanding, Plytech Futura (European Birch HPL), or Plytech Spectrum Eco (Finnish Birch HPL). Prices may vary, please enquire.
- Power Data includes the base unit and an interconnect cable; starters may be required to be sourced locally. Internal routing provided; assumes floor sourced power connection

- Units nest for economical shipping.
- Weight: 60 kg

WORKTOP COLOURS

Standard Melteca



Snowdrift

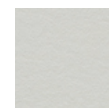

Seal Grey



Sublime Teak

Futura HPL

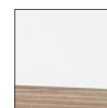

White

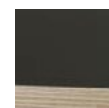

Black

Spectrum Eco

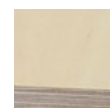

Finnish Birch

Designed and made in New Zealand.

www.plngroup.co.nz