

HUSH MINI LED 110V

Designed by David Trubridge

(1034-A)

pln.

Overall Dimensions - Model: 1034-A (110V)

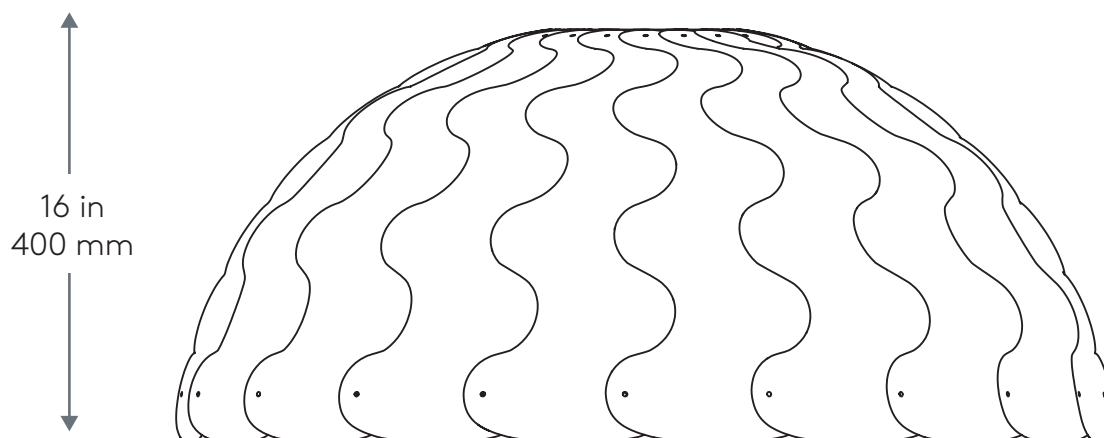
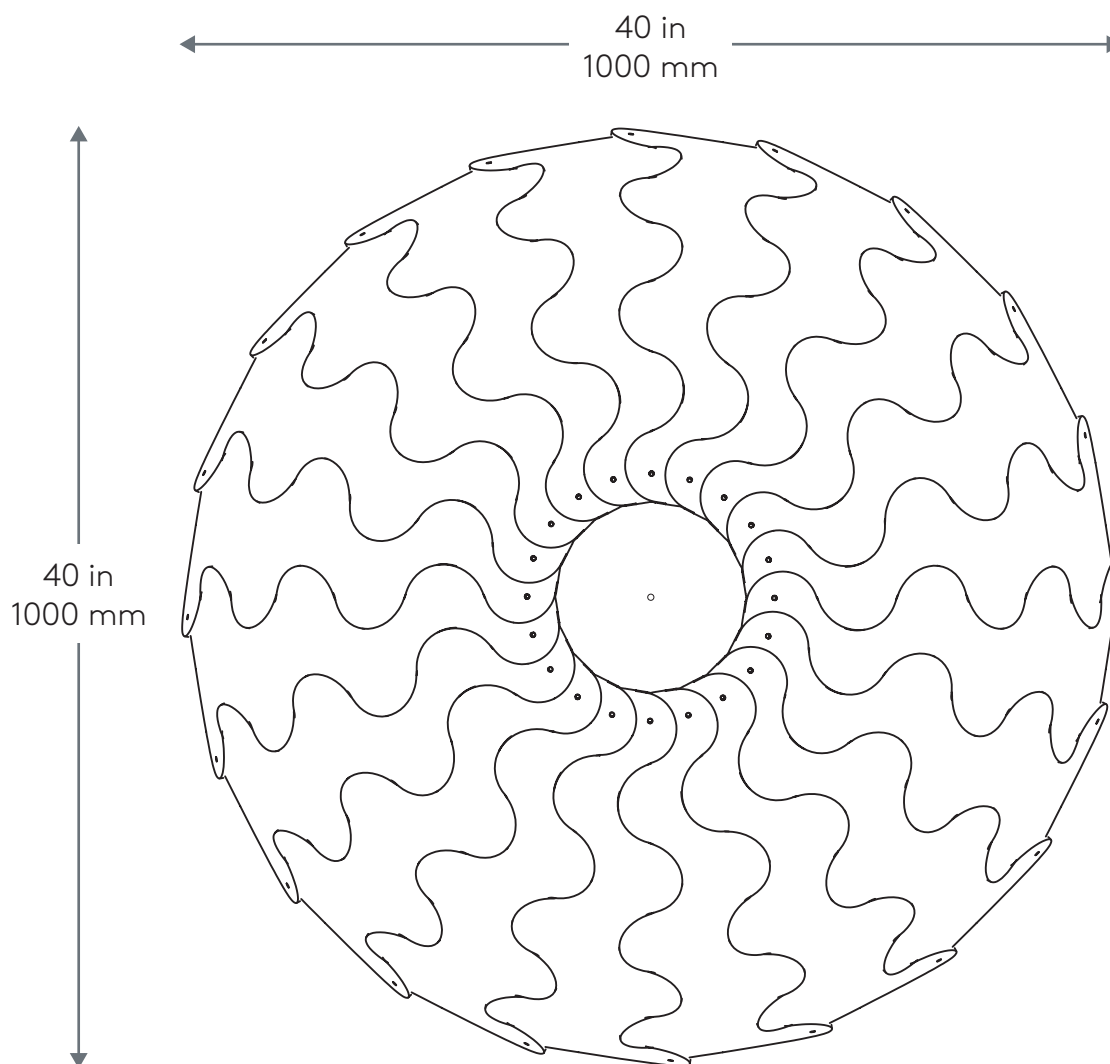

HUSH MINI LED 110V

Designed by David Trubridge

(1034-A)

pln.

Contents (not to scale)

Please double check all components are present and quantities are correct before beginning assembly

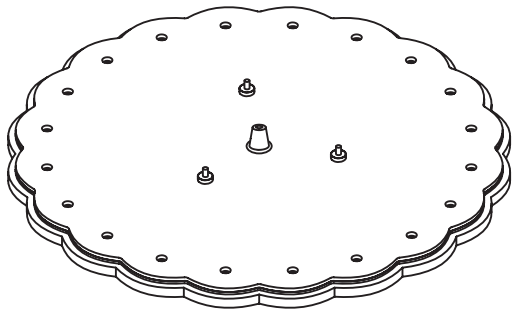

x1
Top Panel Assembly
(LED attached but not shown)

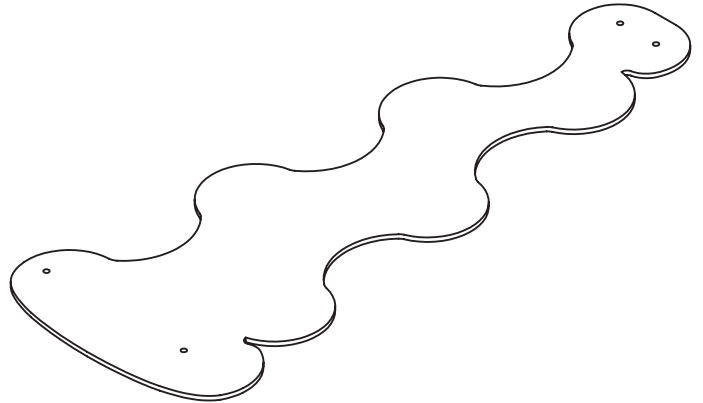

x20
Tapered
Felt Panels

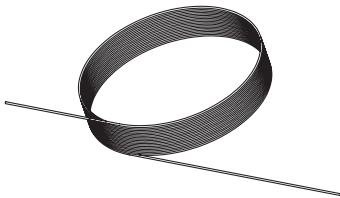

x1
Triple Swage Cable



x40 (+5)
Small Ratchet Rivets
(13mm)



x40 (+5)
Large Ratchet Rivets
(19mm)

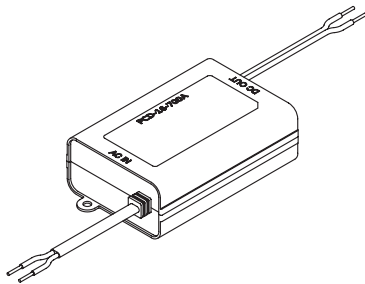

x1
LED Driver
(PCD-16-700A)

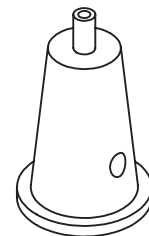

x1
Cone Gripper
with Base

HUSH MINI LED 110V

Designed by David Trubridge
(1034-A)



Step 1 - Top Panel Ratchet Rivet Assembly

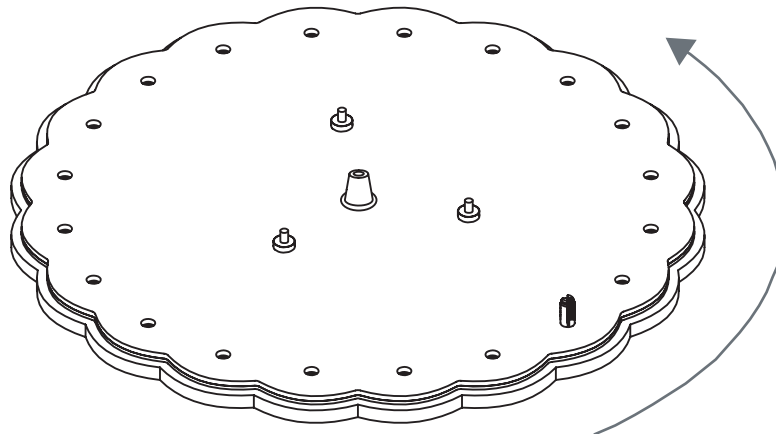
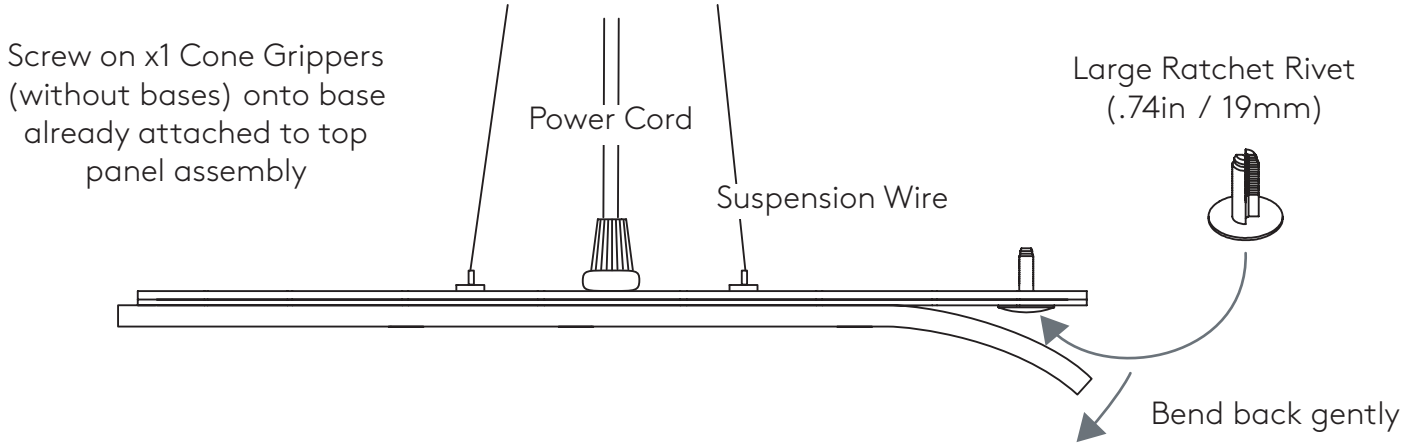

Insert Large Ratchet Rivets (.74in / 19mm) in all holes around edge.

(power cord and suspension wires not shown)

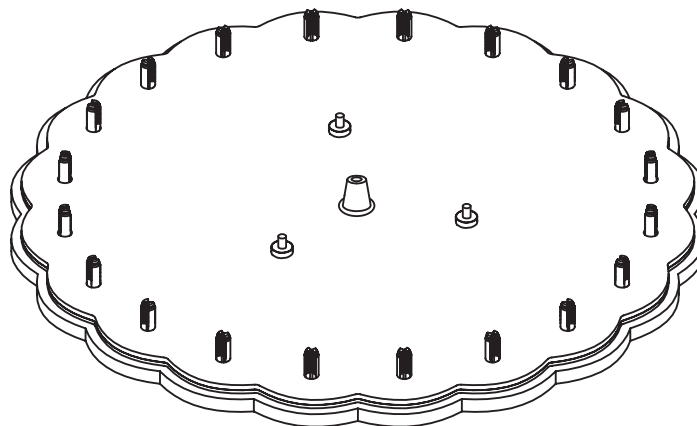

HUSH MINI LED 110V

Designed by David Trubridge

(1034-A)

pln.

Step 2 - Pop out side panel plugs

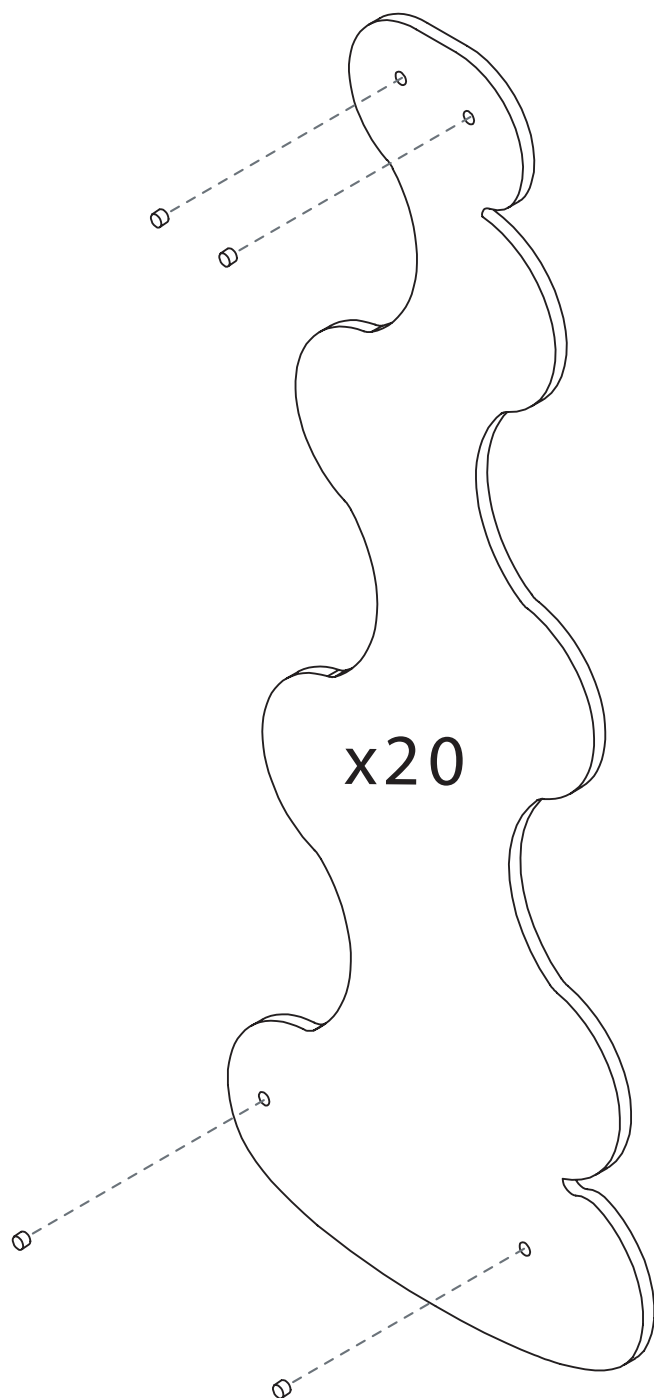

Push out the 4 plugs per panel to make way for the plastic clips.

HUSH MINI LED 110V

Designed by David Trubridge
(1034-A)



Step 3 - Top Panel to Side Panel Assembly

Assemble on a large clean surface or on floor.

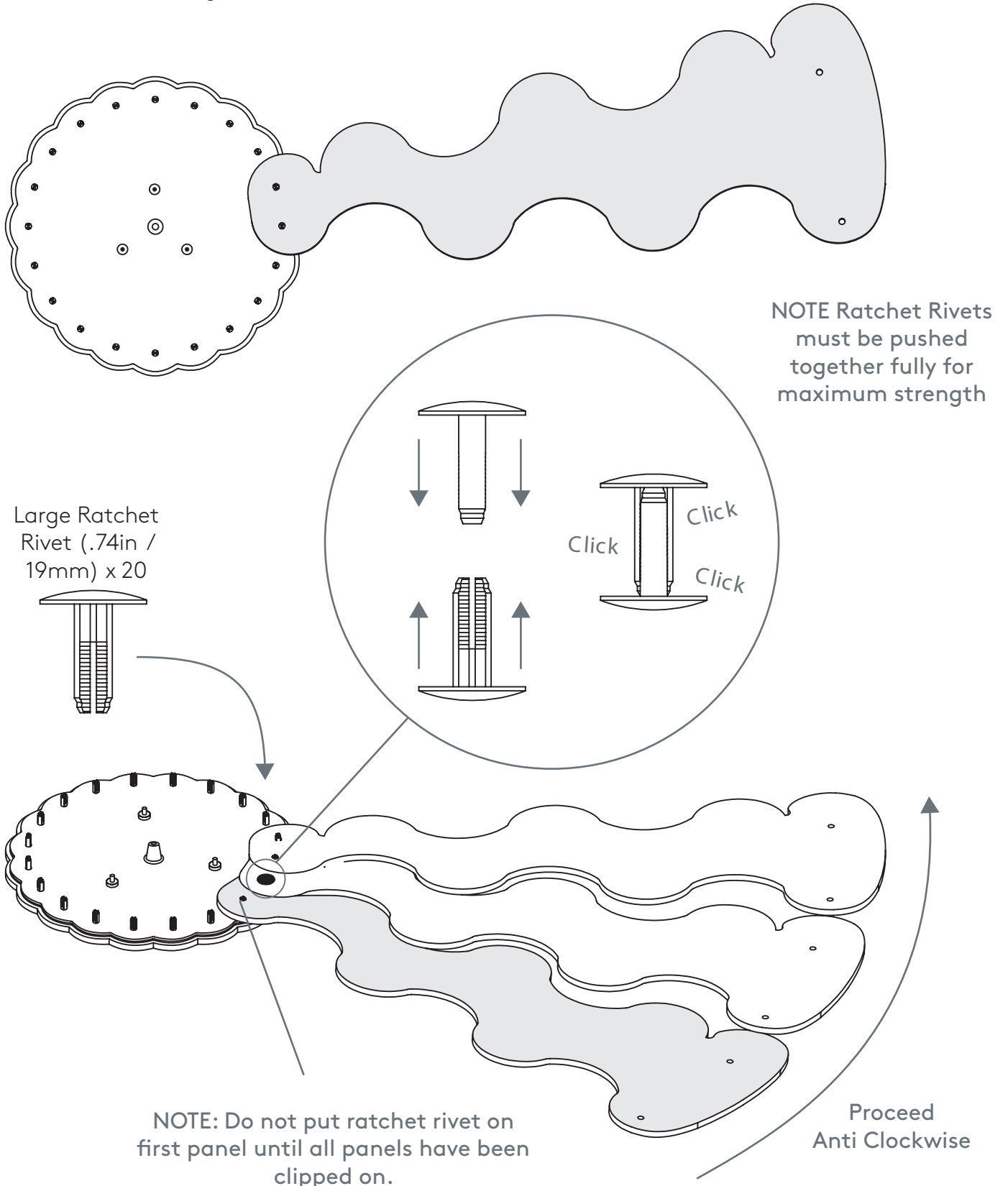

HUSH MINI LED 110V

Designed by David Trubridge

(1034-A)



Step 4 - Top Panel to Side Panel Assembly Continued

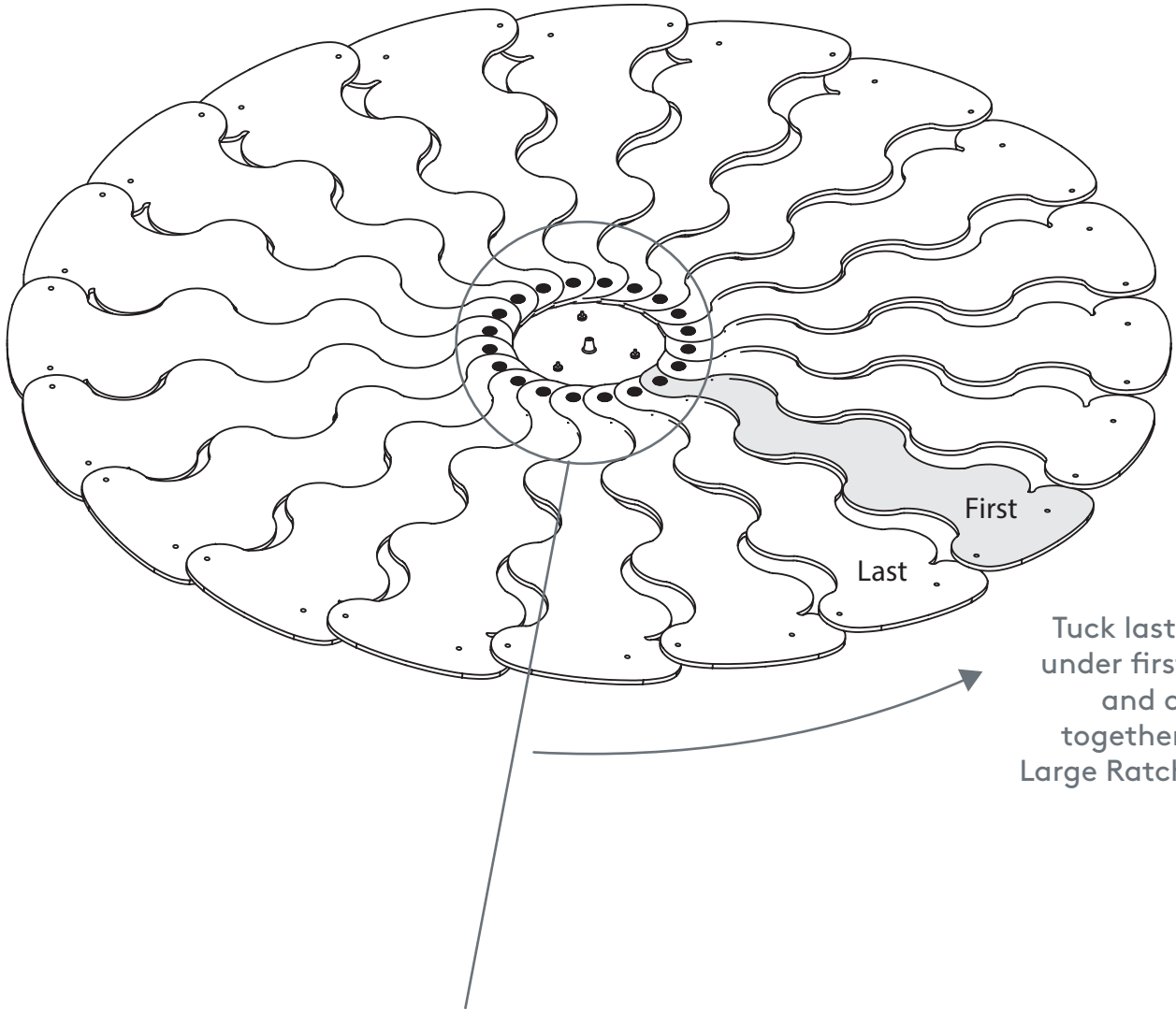

Tuck last panel under first panel and clip together with Large Ratchet Rivet

Cross Section Detail View of Top Panels overlapping.

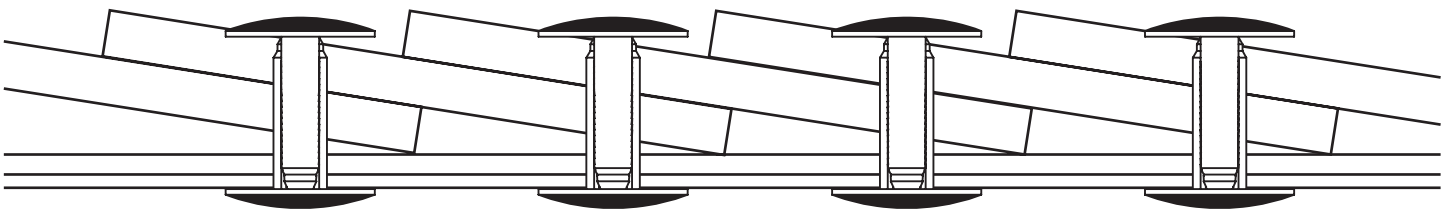

HUSH MINI LED 110V

Designed by David Trubridge
(1034-A)

pln.

Step 5 - Lifting into shape

Use suspension cable to lift the Hush Mini approximately 16 in (400mm) from the floor/surface.

The panels will begin to fall into their natural shape.

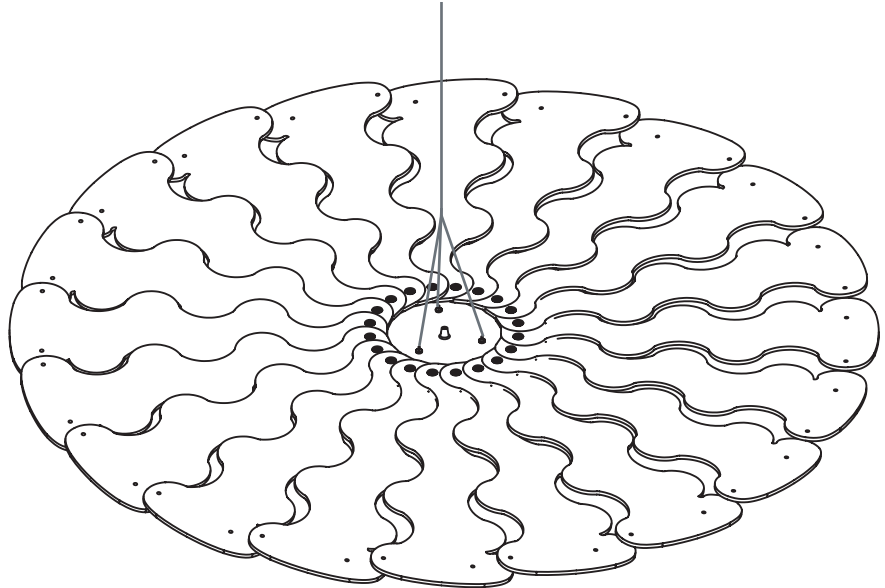

Use the folded cardboard pillar that was in the box (or similar-sized table) to prop it up.

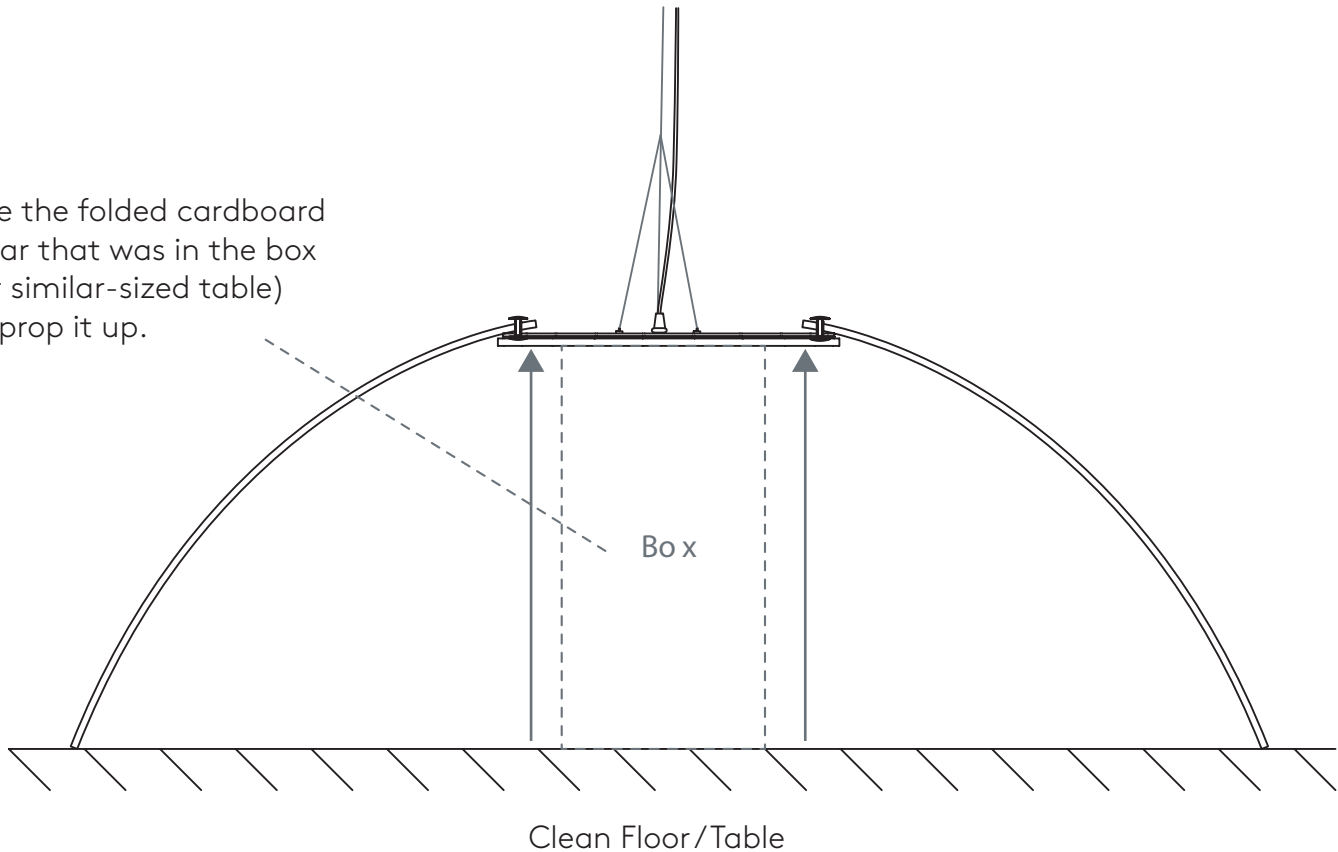

HUSH MINI LED 110V

Designed by David Trubridge

(1034-A)

pln.

Step 6A - Weaving of Panels - Exploded Detail

Bold Lines indicate the 'Ear' that sits on the outside of the Hush Mini.
This weaving pattern is essential to lock the shape together

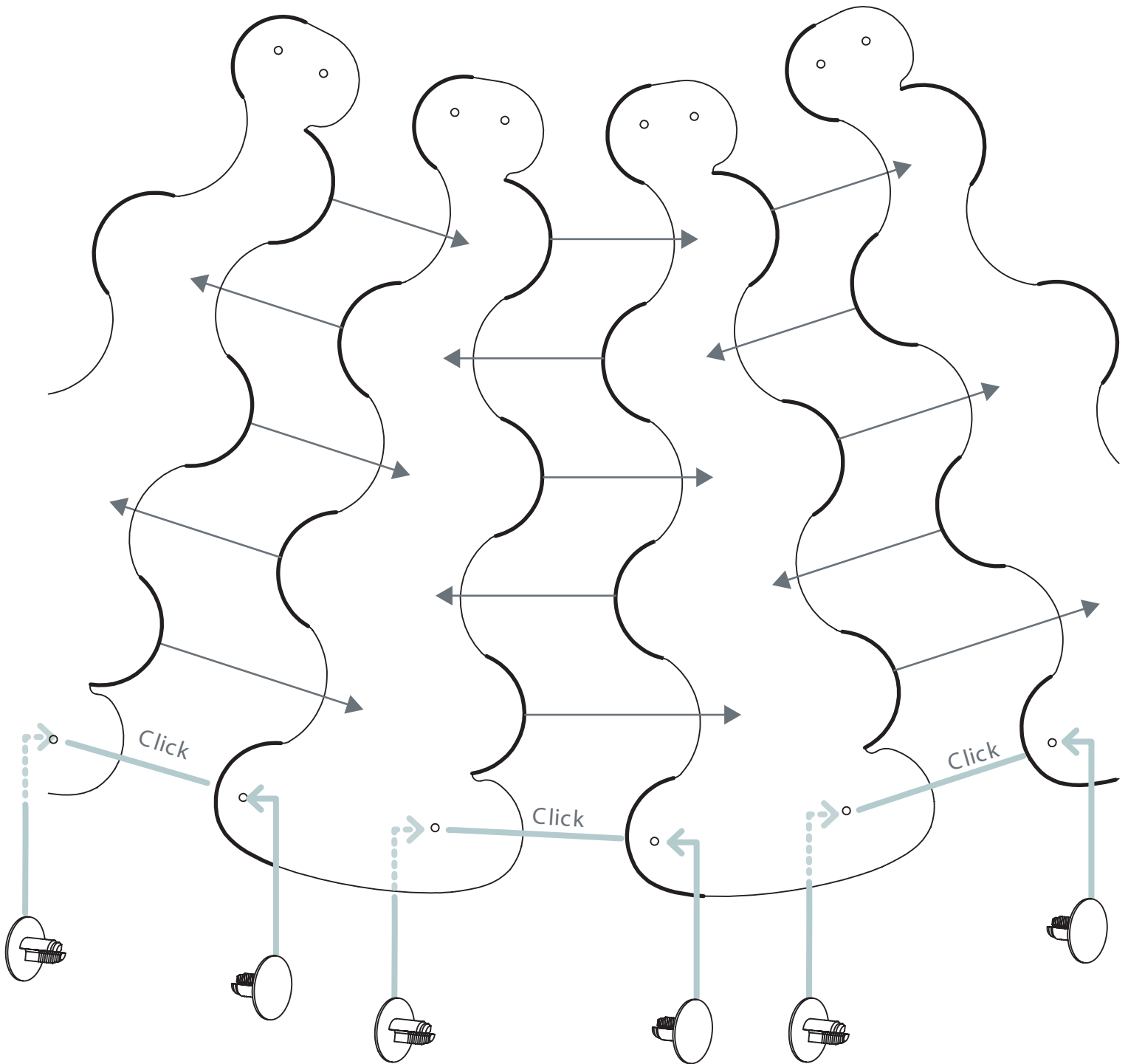

Once two panels are woven together, use two of the shorter Ratchet Rivets (.5 in /13 mm) to lock them together.

HUSH MINI LED 110V

Designed by David Trubridge

(1034-A)

pln.

Step 6A - Weaving of Panels - Finished Detail

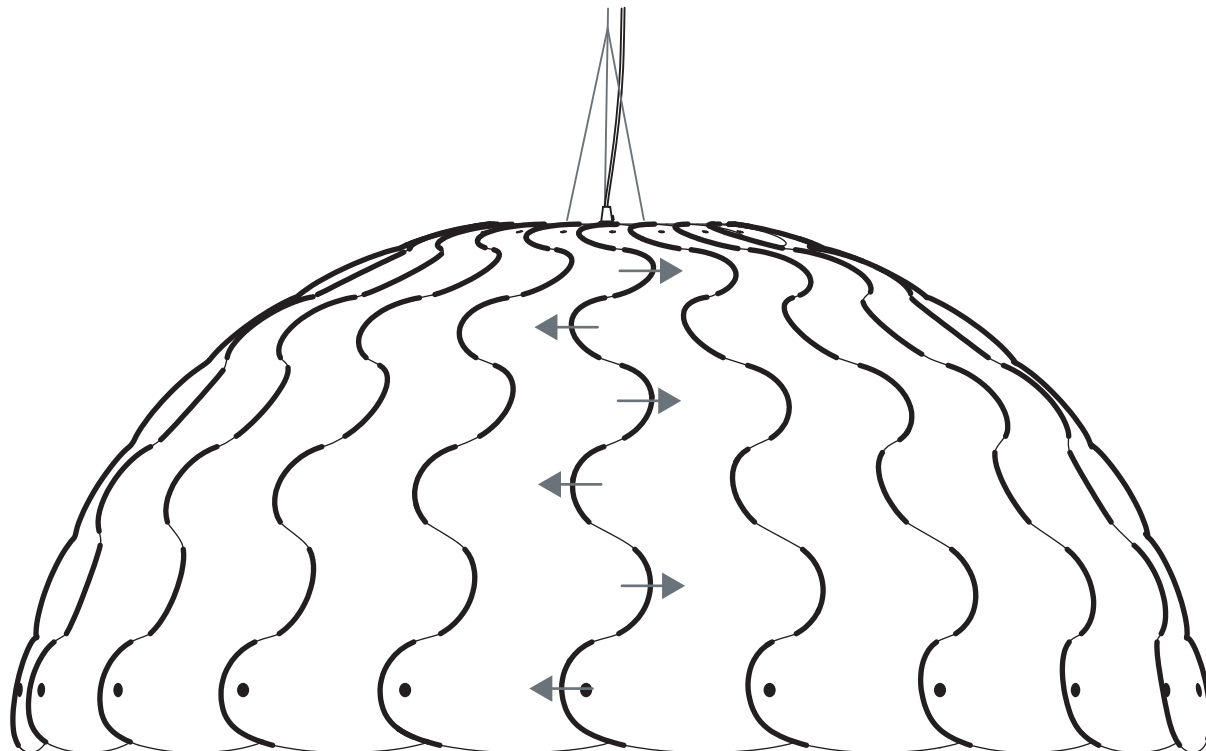

Bold Lines indicate the 'Ear' that sits on the outside of the Hush Mini.
This weaving pattern is essential to lock the shape together

HUSH MINI LED 110V

Designed by David Trubridge

(1034-A)

pln.

Step 7 - Height Adjustment and Levelling

Ceiling Mounting Point.

If installing into wood use a countersunk timber screw (not supplied) to affix cone grip to ceiling.

If installing into concrete use countersunk anchor bolt (not supplied) to affix cone grip to ceiling.

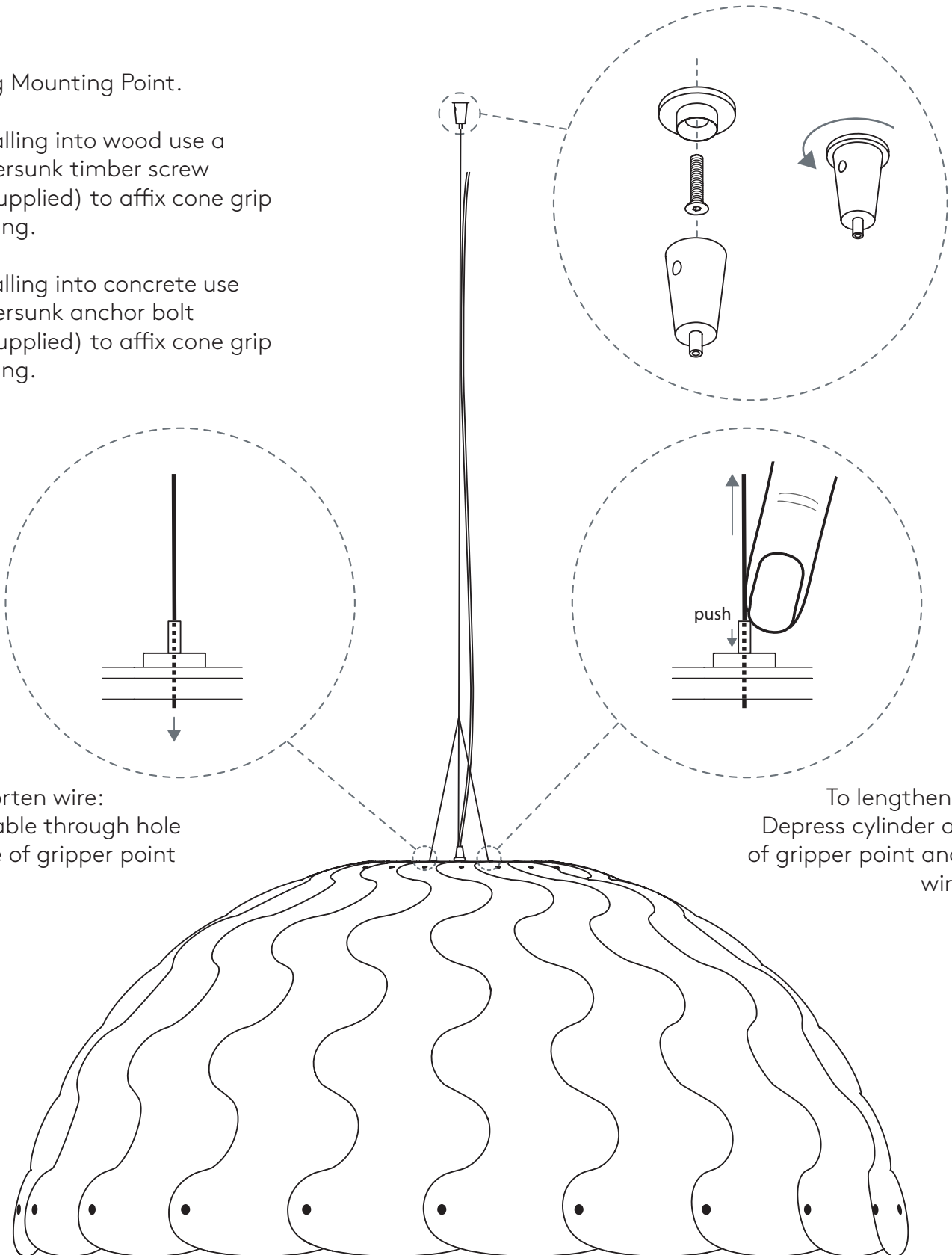

To shorten wire:
Pull cable through hole
in side of gripper point

To lengthen wire:
Depress cylinder at top
of gripper point and pull
wire out

HUSH MINI LED 110V

Designed by David Trubridge

(1034-A)



Step 8 - Electrics, Suggested LED driver placement with hanging ceiling

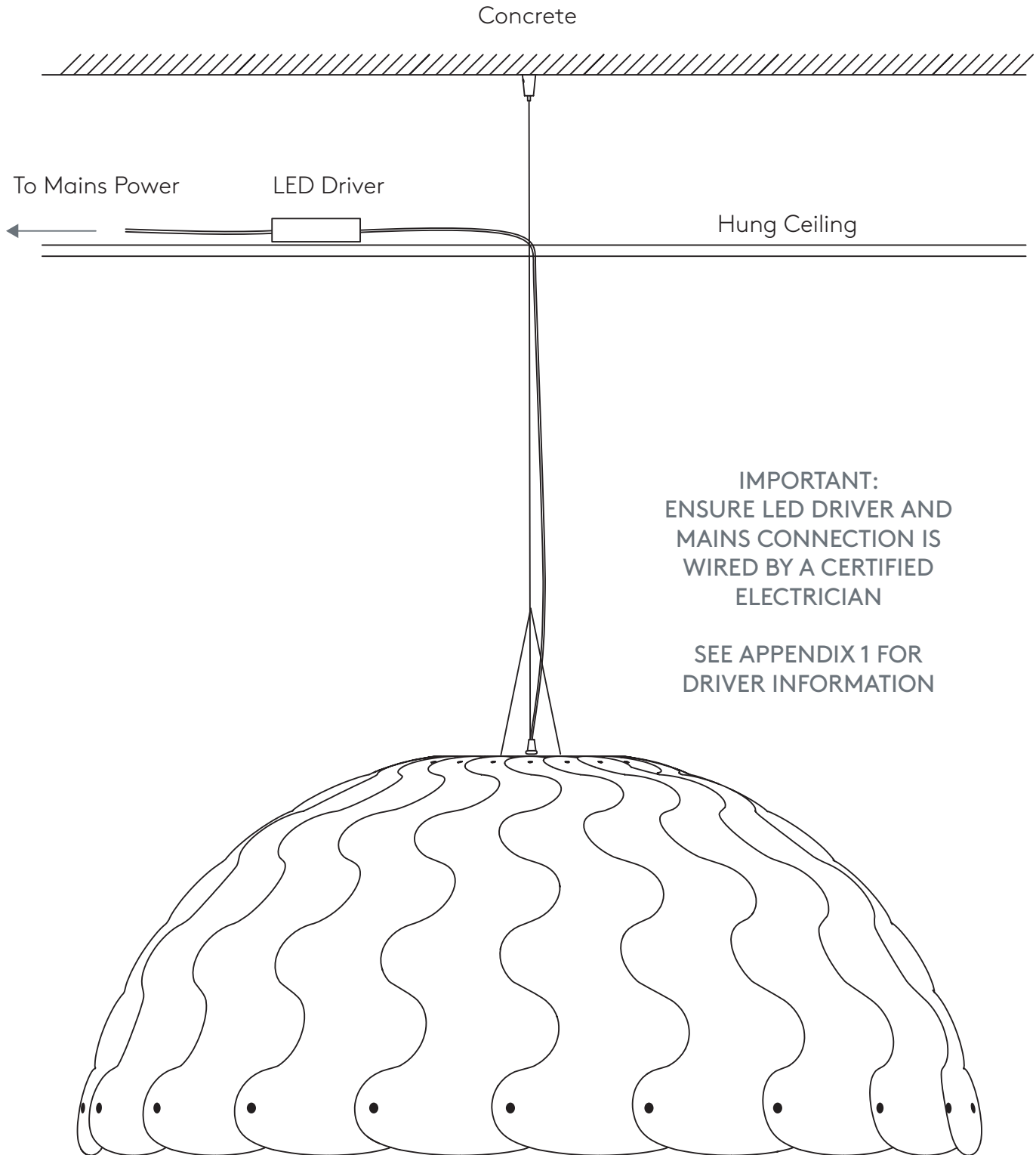

IMPORTANT:
ENSURE LED DRIVER AND
MAINS CONNECTION IS
WIRED BY A CERTIFIED
ELECTRICIAN

SEE APPENDIX 1 FOR
DRIVER INFORMATION

HUSH MINI LED 110V

Designed by David Trubridge

(1034-A)



Appendix 1: LED Driver Diagram

MEANWELL 16W Single Output C Dimmable LED Power Supply
(PCD-16-700A)

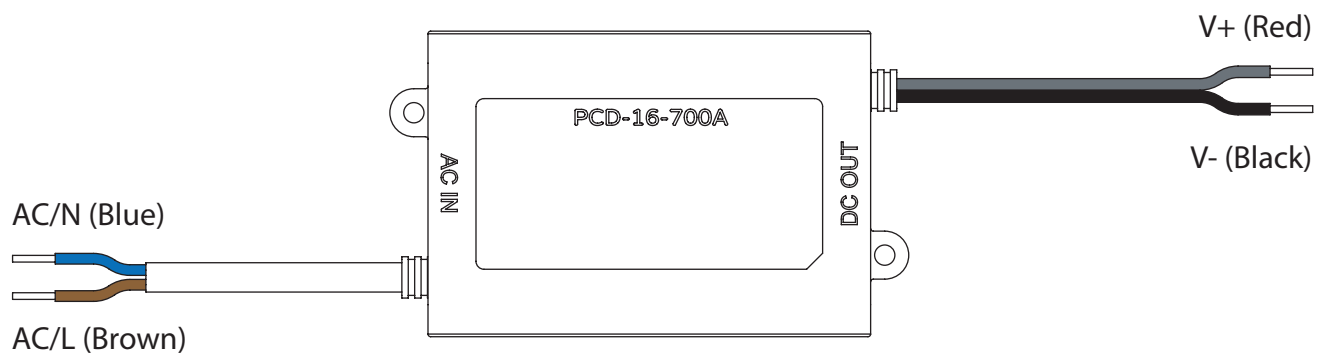

IMPORTANT:
THIS PRODUCT MUST BE INSTALLED IN ACCORDANCE
WITH THE APPLICABLE INSTALLATION CODE BY A
PERSON FAMILIAR WITH THE CONSTRUCTION AND
OPERATION OF THE PRODUCT AND THE HAZARDS
INVOLVED

HUSH MINI LED 110V

Designed by David Trubridge

(1034-A)

pln.

Appendix 2: Access to LED Lights for maintenance

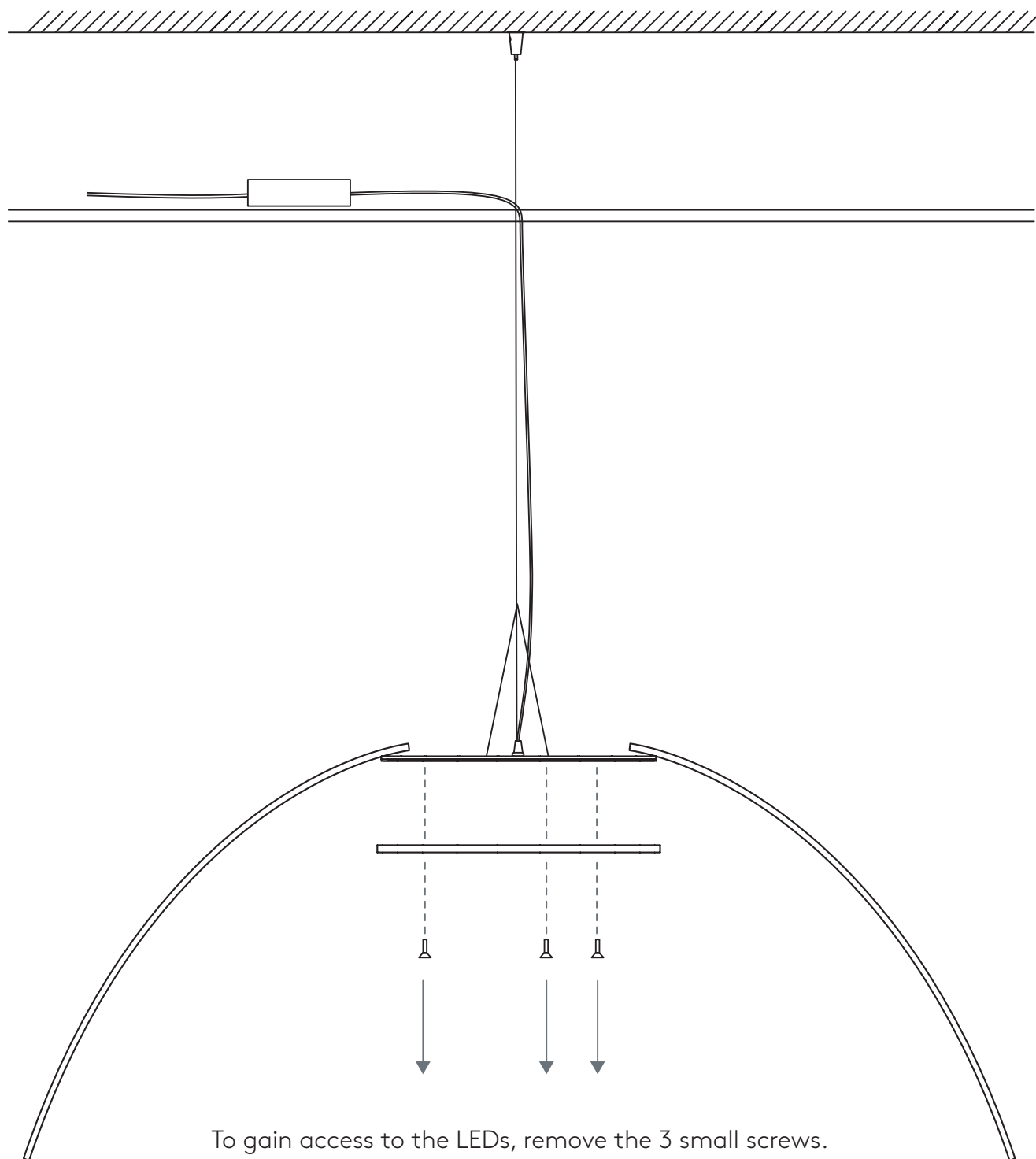

To gain access to the LEDs, remove the 3 small screws.

HUSH MINI LED 110V

Designed by David Trubridge

(1034-A)



Appendix 3: Top Panel Sub Assembly

